



Ansems

aanhangwagens

GT serie

Programmaoverzicht van de verschillende vestigingen van Ansems



Ansems
aanhangwagens
www.anssems.eu

Uw Ansems dealer:

Constructiewijzigingen en drukfouten voorbehouden.

JANUAR 2009



Bad Bentheim

www.anssems.eu



HISTORIE

Anssems Aanhangwagens B.V. produceert al sinds 1977 aanhangwagens. De aanhangwagens worden aanvankelijk alleen in Nederland verkocht, maar al snel komen ook aanvragen uit het buitenland binnen.

In 2003 wordt er in de Duitse plaats Bad Bentheim begonnen met de productie van een nieuwe serie aanhangwagens; de GT serie.

Door een zeer precieze manier van werken, met de modernste technologieën, wordt gewaarborgd dat alle aanhangwagens voldoen aan hoge kwaliteitseisen. Het productieproces wordt nauwgezet gecontroleerd, maar ook iedere aanhangwagen wordt nog apart aan een gedegen eindcontrole onderworpen.

Zo ziet u dat Anssems en kwaliteit onlosmakelijk met elkaar verbonden zijn.

De standaard uitvoering



GT 750-201



GT 750-251 R



GT 750-251 R



GTT 1500-251



GTB 1200-251 R

Veelzijdig te gebruiken

Uitgerust met een stalen reling en voorrek, met een vlakzeil of een huif is de aanhangwagen voor bijna alle doeleinden te gebruiken.

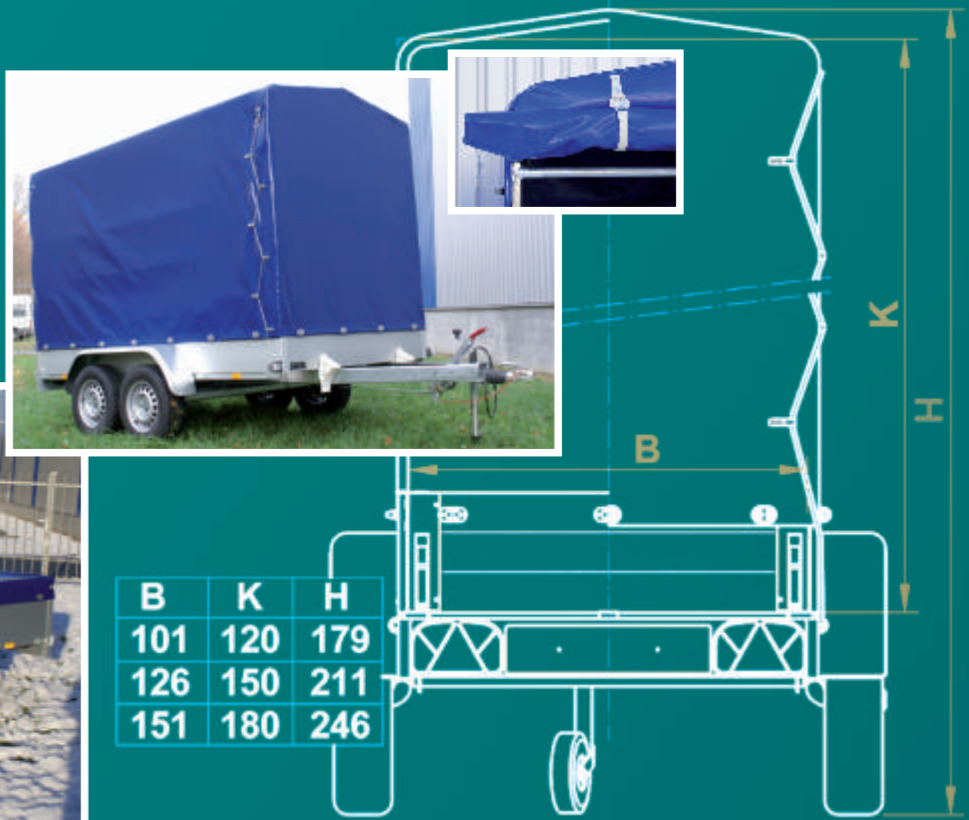



ACCESSOIRES:

De GT aanhangwagens hebben door hun ontwerp weinig rijwindweerstand en zijn...



Deksel



Opzetborden



Stalen reling



Voorrek

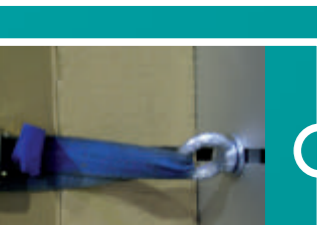

Bindoog

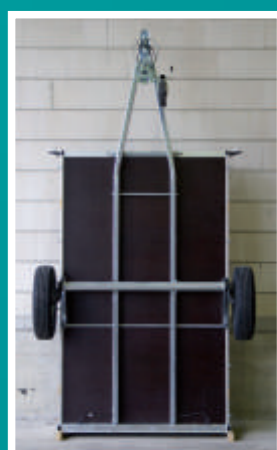

Bij alle GT uitvoeringen loopt de dissel tot achter door zodat de vloer goed ondersteund wordt.



GTT 2000-301 VT 3



GTB 750-211 HT



GT 750-201 VT 1



GTT 2000-301 VT 3

De gesloten aanhangwagens van Anssems



GTB 1200-251



GTT 1500-301 VT 2



GTT 2000-301 VT 3

ACCESSOIRES:



Uitzetpoot



Asschokbrekers

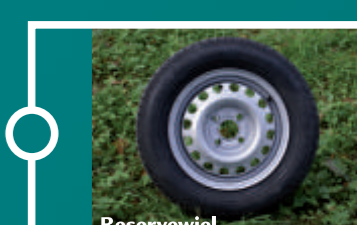

Reservewiel



Reservewielhouders



Reservewielhouder



Vlakzeil



Huif

...comfortabel te laden.

GT – Technische Informatie

Standard

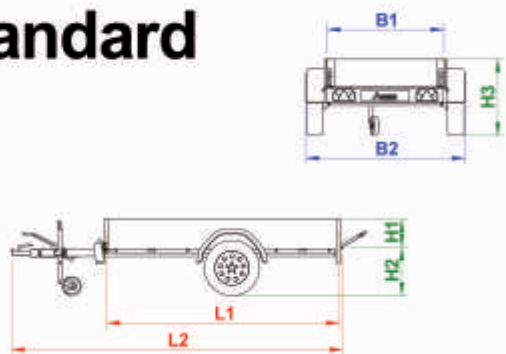

R

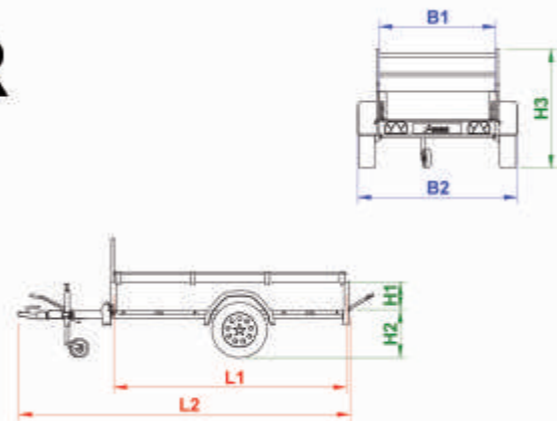

HT

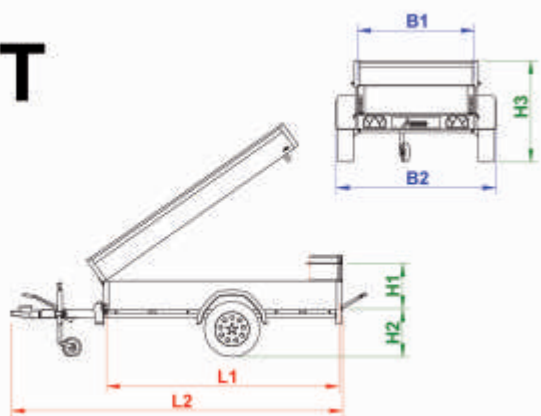

VT1

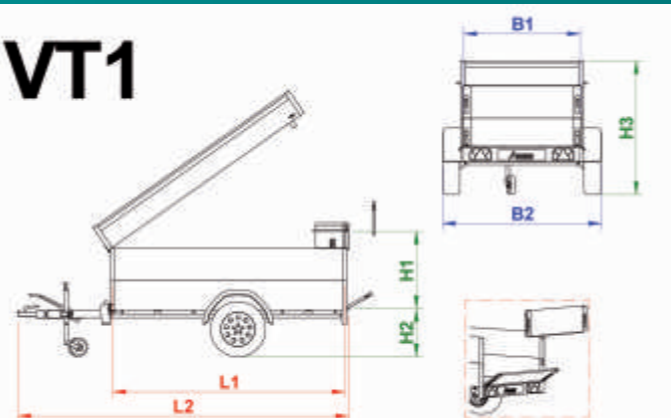

VT2

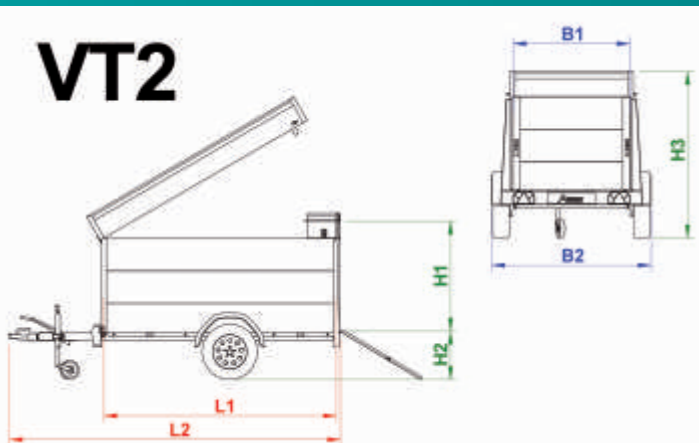

VT3

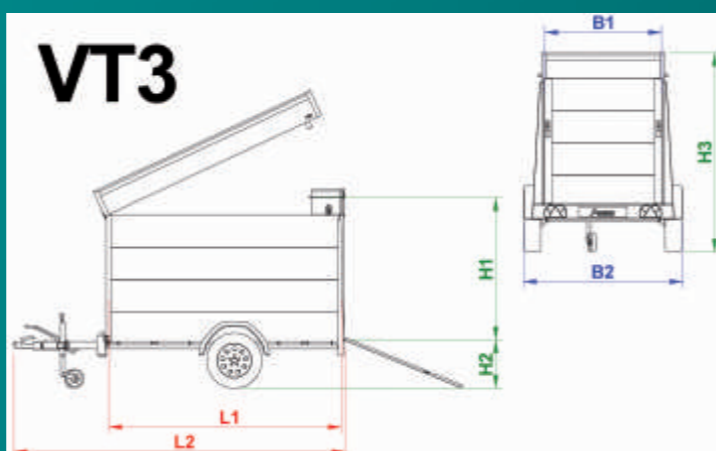

GT-Series Technische Informatie

Omschrijving	Afmetingen Laadvloer L x B x H cm (L1 x B1 x H1)	Totale lengte cm (L2)	Totale breedte cm (B2)	Totale hoogte cm (H3)	Laadvloerhoogte cm (H2)	Totaal draagvermogen kg	Ledig gewicht kg	Laadvermogen kg	Geremd	As (stukks)	Wiel	Neuswiel	Bindoog buiten (stukks)	Deksel aan voorzijde scharnierend	Bindoog binnen (stukks)	Uitzetpoot	Huif
--------------	--	-----------------------	------------------------	-----------------------	-------------------------	-------------------------	------------------	-----------------	--------	-------------	------	----------	-------------------------	-----------------------------------	-------------------------	------------	------

GT – open of met reling en voorrek

Accessoires

GT 500-151 / R ¹	151 x 101 x 30	229	143	79	49	500	110/122	390/378	-	1	R 13	✓	8	-	-	•	• ²
GT 500-181 / R ¹	181 x 101 x 30	279	143	79	49	500	115/128	385/372	-	1	R 13	✓	8	-	-	•	• ²
GT 750-201 / R ¹	201 x 101 x 30	299	143	79	49	750	120/134	630/616	-	1	R 13	✓	8	-	-	•	• ²
GT 750-211 / R ¹	211 x 126 x 30	314	168	79	49	750	140/157	610/593	-	1	R 13	✓	8	-	-	•	• ³
GT 750-251 / R ¹	251 x 126 x 30	354	168	79	49	750	150/168	600/582	-	1	R 13	✓	8	-	-	•	• ³
GTT 750-251 / R ¹	251 x 126 x 30	354	168	79	49	750	240/258	510/492	-	2	R 13	✓	8	-	-	•	• ³
GTB 750-211 / R ¹	211 x 126 x 30	319	168	79	49	750	155/172	595/578	✓	1	R 13	✓	8	-	-	•	• ³
GTB 750-251 / R ¹	251 x 126 x 30	359	168	79	49	750	165/183	585/567	✓	1	R 13	✓	8	-	-	•	• ³
GTB 1200-251 / R ¹	251 x 126 x 30	359	173	79	49	1160	195/213	965/947	✓	1	R 13	✓	8	-	-	•	• ³
GTB 1200-301 / R ¹	301 x 126 x 30	409	173	79	49	1160	205/224	955/936	✓	1	R 13	✓	8	-	-	•	• ³
GTT 1500-251 / R ¹	251 x 126 x 30	359	173	79	49	1500	240/258	1260/1242	✓	2	R 13	✓	8	-	-	•	• ³
GTT 1500-301 / R ¹	301 x 126 x 30	409	173	79	49	1500	250/269	1250/1231	✓	2	R 13	✓	8	-	-	•	• ³
GTT 2000-301 / R ¹	301 x 151 x 30	409	198	81	51	2000	340/364	1660/1636	✓	2	R 13	✓	8	-	-	•	• ⁴

GT – HT (met deksel)

Accessoires

GT 500-151 HT	151 x 101 x 48	229	143	109	49	500	139	361	-	1	R 13	✓	8	✓	-	•	-
GT 500-181 HT	181 x 101 x 48	279	143	109	49	500	148	352	-	1	R 13	✓	8	✓	-	•	-
GT 750-201 HT	201 x 101 x 48	299	143	109	49	750	156	594	-	1	R 13	✓	8	✓	-	•	-
GT 750-211 HT	211 x 126 x 48	314	168	109	49	750	182	568	-	1	R 13	✓	8	✓	-	•	-
GT 750-251 HT	251 x 126 x 48	354	168	109	49	750	198	552	-	1	R 13	✓	8	✓	-	•	-
GTB 750-211 HT	211 x 126 x 48	319	168	109	49	750	197	553	✓	1	R 13	✓	8	✓	-	•	-
GTB 1200-251 HT	251 x 126 x 48	359	173	109	49	1160	243	917	✓	1	R 13	✓	8	✓	-	•	-

GT – VT1 (Binnenhoogte 83 cm)

Accessoires

GT 500-181 VT1	181 x 101 x 83	279	143	144	49	500	188	312	-	1	R 13	✓	8	✓	2	•	-
GT 750-201 VT1	201 x 101 x 83	299	143	144	49	750	198	552	-	1	R 13	✓	8	✓	2	•	-
GTB 750-211 VT1	211 x 126 x 83	319	168	144	49	750	240	510	✓	1	R 13	✓	8	✓	2	•	-
GTB 1200-251 VT1	251 x 126 x 83	359	173	144	49	1160	290	870	✓	1	R 13	✓	8	✓	2	•	-

GT – VT2 (Binnenhoogte 118 cm)

Accessoires

GTB 750-211 VT2	211 x 126 x 118	319	168	179	49	750	268	482	✓	1	R 13	✓	8	✓	4	✓	-
GTB 1200-251 VT2	251 x 126 x 118	359	173	179	49	1160	321	839	✓	1	R 13	✓	8	✓	4	✓	-
GTT 1500-301 VT2	301 x 126 x 118	409	173	179	49	1500	390	1110	✓	2	R 13	✓	8	✓	4	✓	-

GT – VT3 (Binnenhoogte 153 cm)

Accessoires

GTB 1200-251 VT3	251 x 126 x 153	359	173	214	49	1160	341	819	✓	1	R 13	✓	8	✓	6	✓	-
GTT 2000-301 VT3	301 x 151 x 153	409	198	216	51	2000	490	1510	✓	2	R 13	✓	8	✓	6	✓	-

- 1) Aanhangwagens met een R worden met voorrek (hoogte 40 cm) en reling (hoogte 10 cm) geleverd.
 - 2) Huiven zijn leverbaar in 120 cm hoogte.
 - 3) Huiven zijn leverbaar in 150 cm hoogte.
 - 4) Huiven zijn leverbaar in 180 cm hoogte.
-) ongemonteerd leverbaar
 - ✓) standaard